



# **Campbell Collegiate Course Catalogue 2018/2019**

## **Grades 10 through 12**

<b>English Language Arts Courses .....</b>	<b>1</b>
<b>Mathematics Courses .....</b>	<b>3</b>
<b>Science Courses.....</b>	<b>6</b>
<b>Social Studies Courses.....</b>	<b>8</b>
<b>Fine Arts Courses .....</b>	<b>10</b>
<b>Physical Education, Health and Wellness Courses.....</b>	<b>13</b>
<b>Practical and Applied Arts Courses.....</b>	<b>14</b>
<b>Core French, German and Spanish Courses.....</b>	<b>20</b>
<b>French Immersion Courses.....</b>	<b>21</b>

———— ENGLISH LANGUAGE ARTS COURSES ————

**English Language Arts – all ELA courses have the options of regular, AP and modified programming.**

Five English Language Arts credits are required for graduation, not including English Language Arts electives (Media Studies 20, Communication Studies 20, Journalism 20, Creative Writing 20, English Literature and Composition 20L [AP]).

The K-12 aim of the Saskatchewan English language arts curricula is to help students understand and appreciate language, and to use it confidently and competently in a variety of situations for learning, communication, work, life, and personal satisfaction. The K-12 areas of the Saskatchewan English language arts curricula are:

- **Comprehend and Respond (CR):** Students will extend their abilities to view, listen to, read, comprehend, and respond to a variety of contemporary and traditional grade-level-appropriate texts in a variety of forms (oral, print, and other texts) from First Nations, Métis, and other cultures for a variety of purposes including for learning, interest, and enjoyment.
- **Compose and Create (CC):** Students will extend their abilities to speak, write, and use other forms of representation to explore and present thoughts, feelings, and experiences in a variety of forms for a variety of purposes and audiences.
- **Assess and Reflect (AR):** Students will extend their abilities to assess their own language skills; discuss the skills of effective viewers, listeners, readers, representers, speakers, and writers; and set goals for future improvement.

The literature used in English Language Arts classes spans novels, plays, poetry, short stories, non-fiction texts, and informational texts.

**ELA A10:**

*Prerequisite:* ELA 9

**The Challenges of Life:** Explaining the World through our Foundational Stories; Destiny and Challenges of Life; Human Existence; Decisions

**The Mysteries of Life:** The Joys of Mind, Body, and Spirit; Mysteries of the Human Brain and Imagination; Mysteries of this World and Beyond; The Fantastic

**ELA B10:**

*Prerequisite:* ELA 9

**Equity and Ethics:** Who and What is Right?; Empowerment; Degrees of Responsibility; Rights and Responsibilities; Justice and Fairness

**The World Around and Within Us:** Perspectives; Diversity of Being; The Natural and the Constructed Worlds; Individuals and Communities; Stewardship

**ELA 20:**

*Prerequisite:* ELA A10 and B10

**Starting Out – Beginning and Becoming:** The Past and the Present; Triumphs and Trials; Discovery and Disillusionment; Relationships with Family and Others; Celebrations and Rites of Passage

**Moving Forward – Establishing and Realizing:** Turning Points and Transitions; Evolving Roles and Responsibilities; Opportunities and Obstacles; Risks and Rewards; Beliefs and Goals

**ENGLISH LITERATURE AND COMPOSITION 20L (AP):**

*Prerequisite:* ELA A10 and ELA B10

\*elective

\*This course is offered in second semester for ELA AP students. It is *strongly* recommended that students complete ELA 20 with an AP teacher before registering in this course.

English Literature and Composition 20L is designed to support students seeking enriched programming and to support students in preparing for the Advanced Placement English Literature and Composition exam. This course is intended to be offered as a supplement to the Saskatchewan

Ministry of Education English Language Arts program.

**CREATIVE WRITING 20:**

*Prerequisite:* ELA A10 and ELA B10

\*elective

This course provides opportunities for students to refine their creative writing skills and abilities beyond those developed in the required ELA courses. This course encourages students to see creative writing as a unique way of thinking, and as a means of constructing and conveying meaning.

**MEDIA STUDIES 20:**

*Prerequisite:* ELA A10 and ELA B10

\*elective

The purpose of this course is to develop the knowledge, skills, and disposition students need in order to understand and use media as informed and active citizens. Students will develop an informed and critical understanding of the nature of mass media, the techniques used by them, and the impact of these media.

**ELA A30:**

*Prerequisite:* ELA 20

**Canadian Perspectives: Distinct and Rich:** Define the Individual, Negotiate the Community; Celebrate the Glorious, Acknowledge the Scandalous; Shift Centres, Blur Margins; Understand Beliefs, Initiate Action

**Canadian Landscapes: Diverse and Dynamic:** Natural and Constructed; Psychological and Physical; Historical and Contemporary; Personal and Societal

**ELA B30:**

*Prerequisite:* ELA 20

**The Search for Self:** Sense of Self; Ideals; Joy and Inspiration; Doubt and Fear

**The Social Experience:** Dealing with Universal Issues; Ambition, Power, and the Common Good; Social Criticism; Addressing the Issues

**ELA Pathway – please note that the EL&C 20L and AP Lit and Comp Exam are only required for AP students.**

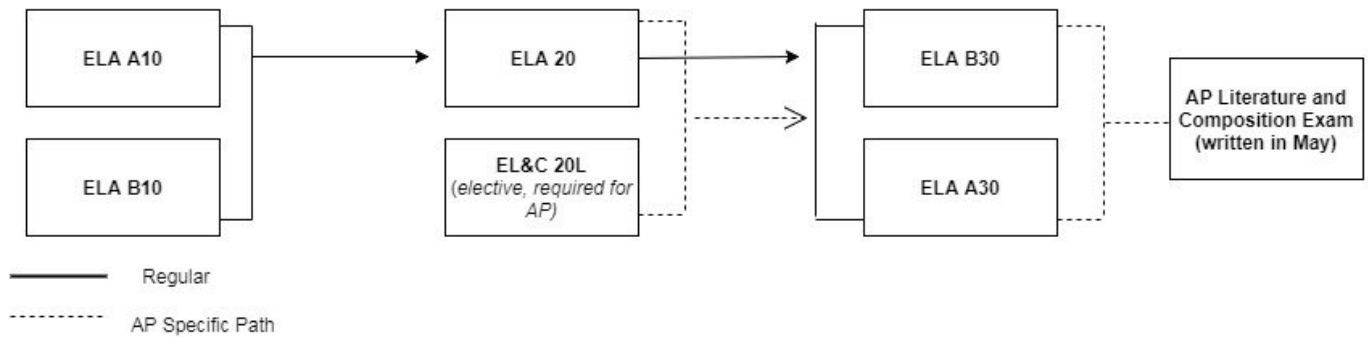

———— MATHEMATICS COURSES ————

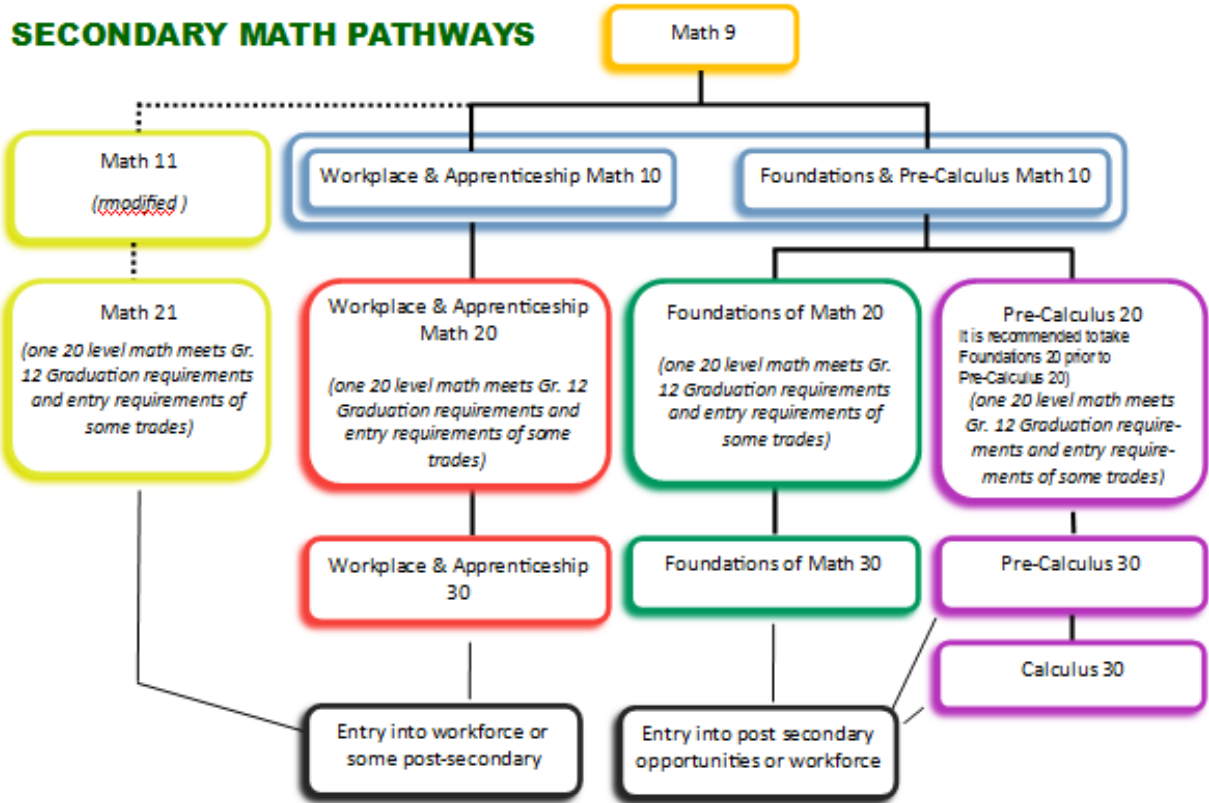

Advanced Placement Pathway: AP Calculus (AB)		
GRADE 10	GRADE 11	GRADE 12
Pre-AP Foundations & Pre-Calculus Math 10	Pre-AP Pre-Calculus 20	AP Calculus 30
Pre-AP Foundations of Math 20	Pre-AP Pre-Calculus 30	AP Calculus 30L
		<b>AP Calculus (AB) Exam Written in May</b>

**MATH PATHWAYS DEFINED**

<b>Modified Math</b>	<b>Workplace &amp; Apprenticeship Math</b>	<b>Foundations Math</b>	<b>Pre-Calculus/Calculus</b>	<b>Advanced Placement (AP)</b>
Placement of students in this pathway is recommended after students' academic strengths and weaknesses are determined through formal and informal means. The content of this course is designed around practical math situations.	This pathway is designed to provide students with the mathematical understandings and critical-thinking skills identified for entry into the majority of trades and for direct entry into the workforce.	This pathway is designed to provide students with the mathematical understandings and critical-thinking skills identified for post-secondary studies in programs that do not require the study of theoretical calculus.	This pathway is designed to provide students with the mathematical understandings and critical-thinking skills identified for post-secondary studies in programs that require the study of theoretical calculus.	This rigorous pathway is designed to provide students with advanced mathematical understandings and critical-thinking skills required for post-secondary studies. In addition to earning high school credits, students in this pathway write the AP Exam in grade 12, which, if passed, can earn them a University Calculus credit.

- The Ministry of Education recommends that students take both Workplace & Apprenticeship 10 and Foundations and Pre-Calculus 10 to give them exposure to both Pathways of Mathematics. This will also ease transitions for those students to change pathways during their high school years.
- Graduation requirement for mathematics is any 20 level course (or Math 21)
- Students can take more than one pathway at the 20 and 30 level.
- *It is the responsibility of the student and parents to check course and entrance requirements with specific post-secondary institutions.*

**Considerations when selecting math courses in grades 10 – 12:**

- Math 11 and 21 are modified courses which are designed for students who struggle with Math.
- There are three pathways for students who do not require modified Math courses: Workplace and Apprenticeship Mathematics, Foundations of Mathematics and Pre-Calculus. Each pathway is designed to provide students with the mathematical understandings, rigour and critical-thinking skills that have been identified for specific post-secondary programs of study and for direct entry into the work force. The content of each pathway has been based on the *Western and Northern Canadian Protocol (WNCP)*.
  - **Workplace and Apprenticeship Mathematics** – This pathway is designed to provide students with the mathematical understandings and critical-thinking skills identified for entry into the majority of trades and for direct entry into the work force.
  - **Foundations of Mathematics** – This pathway is designed to provide students with the mathematical understandings and critical-thinking skills identified for post-secondary studies in programs that do not require the study of theoretical calculus.
  - **Pre-calculus** – This pathway is designed to provide students with the mathematical understandings and critical-thinking skills identified for entry into post-secondary programs that require the study of theoretical calculus.
- The Ministry of Education and Regina Public Schools recommend that Grade 10 students take both Workplace and Apprenticeship Mathematics 10 and the Common Course for Foundations of Mathematics and Pre-Calculus 10.
- There is no hierarchy among the three pathways. They are different types of mathematics for different purposes. Students choose the appropriate math pathway(s) based on what best meets their interests and needs after high school.
- Students may receive credits for more than one math courses at any grade level (except Math 11 and 21). Most students select two pathways so that they develop a wider skill set and study math in both semesters.
- While only a 20-level math course is required for graduation, most students complete a 30-level Math course.

**MATH 11**

Prerequisite: Math 9

Math 11 is a modified course designed for students who struggle with math. Students should receive a recommendation from their math teacher in order to register for Math 11. Students who successfully complete Math 11 will proceed to Math 21.

**MATH 21**

Prerequisite: Math 11

Math 21 is a modified course designed for students who struggle with math. Students should receive a recommendation from their math teacher in order to register for Math 21. This course includes many of the same topics as Math 20 but in less depth. Students who successfully complete Math 21 have met the minimum graduation requirement for math. In order to take further math courses, the student would have to register in Apprenticeship and Workplace Mathematics 10 or Foundations of Mathematics and Pre-Calculus 10.

**WORKPLACE AND APPRENTICESHIP MATHEMATICS 10/20**

Prerequisite: Math 9

The topics include units of measure, spatial thinking, Pythagorean Theorem, polygons and similarity, trigonometry, parallel and perpendicular lines, geometric constructions, proportional reasoning, income and formula manipulation. Students who successfully complete Workplace and Apprenticeship Mathematics 10 and 20.

**YEARLONG WORKPLACE AND APPRENTICESHIP MATHEMATICS 10/20**

Prerequisite: Math 9

This section of Workplace and Apprenticeship Mathematics 10 will be delivered over both semesters. The students will cover the same topics and receive the same credit.

**WORKPLACE AND APPRENTICESHIP MATHEMATICS 20**

Prerequisite: Workplace and Apprenticeship Mathematics 10

The topics include slope and rates of change; graphical representations; measurement; right triangle trigonometry; scale representations, financial services; and personal budgets. Students who successfully complete Workplace and Apprenticeship Mathematics 20 have met the minimum graduation requirement for Math and may choose to proceed to Workplace and Apprenticeship Mathematics 30.

**FOUNDATIONS OF MATHEMATICS 20**

Prerequisite: Common Course for Foundations of Mathematics and Pre-Calculus 10

The topics include inductive and deductive reasoning; properties of angles and triangles; triangle trigonometry; statistical reasoning; systems of linear inequalities; quadratic functions and equations; and proportional reasoning. Students who successfully complete Foundations of Mathematics 20 have met the minimum graduation requirement for Math and may choose to proceed to Foundations of Mathematics 30.

**PRE-CALCULUS 20**

Prerequisite: Common Course for Foundations of Mathematics and Pre-Calculus 10

The topics include sequences and series; trigonometry; quadratic functions and equations; radical expressions and equations; rational expressions and equations; absolute value and reciprocal functions; systems of equations; and linear and quadratic inequalities. Students who successfully complete Pre-Calculus 20 have met the minimum graduation requirement for Math and may choose to proceed to Pre-Calculus 30.

**WORKPLACE AND APPRENTICESHIP MATHEMATICS 30**

Prerequisite: Workplace and Apprenticeship Mathematics 20

The topics include linear relations; limits to measurement; statistics; probability and odds; properties of geometric figures; transformations; trigonometry; and owning a small business.

**FOUNDATIONS OF MATHEMATICS 30**

Prerequisite: Foundations of Mathematics 20

The topics include financial mathematics; set theory and logic; counting methods; probability; polynomial functions; exponential and logarithmic functions; and sinusoidal functions.

**PRE-CALCULUS 30**

Prerequisite: Pre-Calculus 20

The topics include function transformations; radical, polynomial, rational, exponential, and logarithmic functions; the unit circle and trigonometric functions; function operations; and permutations, combinations and the Binomial Theorem. Students who successfully complete Pre-Calculus 30 may choose to proceed to Calculus 30.

**CALCULUS 30**

Prerequisite: Pre-Calculus 30

The topics include limits; derivatives and applications; curve sketching, area under curves, and integrals. This course is recommended for students who plan to take first-year Calculus at university.

**CALCULUS 30L (For AP Calculus Students Only)**

Prerequisite: Calculus 30

Integral Calculus 30L is primarily concerned with developing student understanding of the concepts of calculus and providing experience with its methods and applications. The course emphasizes a multi-representational approach to calculus, with concepts, results and problems being expressed graphically, numerically, analytically, and verbally. Outcomes include approximation methods, derivatives of inverse trigonometric functions, extended integration techniques, volumes of solids, non-geometric applications of integration, elementary single variable calculus theorems, differential equations and slope fields and L'Hopital's rule.

SCIENCE COURSES

## Secondary Science Courses / Prerequisites

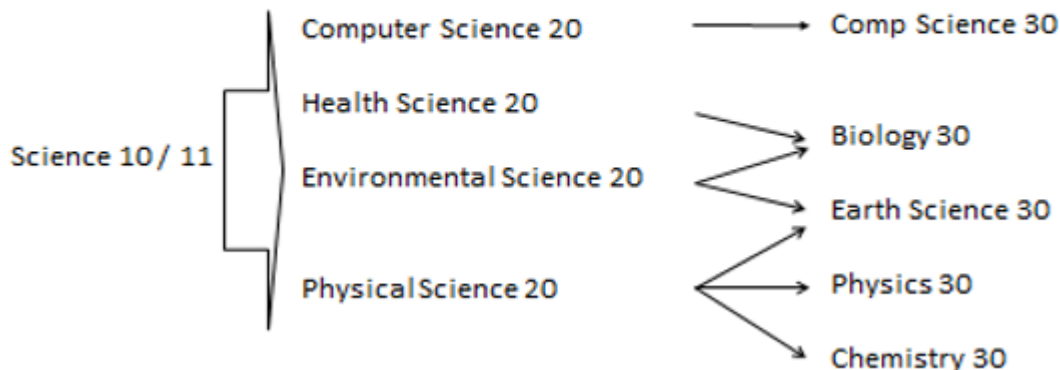

## AP Science Pathways

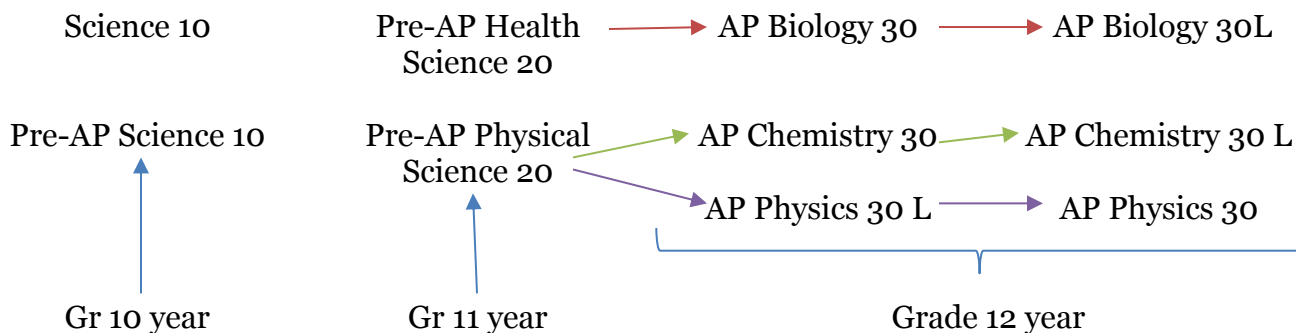

**SCIENCE 10**

Prerequisite: Complete Grade 9

The class is a general science course following the Pan Canadian Curriculum. The curriculum consists of 3 units: Climate and Ecosystems Dynamics, Chemical Reactions and Force and Motion in our World. Students develop skills in mathematical reasoning, scientific investigations, forming hypotheses, drawing good conclusions, graphing and analyzing data. There is an emphasis on developing scientific literacy, which involves science-related attitudes, skills and knowledge students need to improve their inquiry and problem-solving abilities.

Text: *Nelson Science 10*

**HEALTH SCIENCE 20**

Prerequisite: Science 10

This course will challenge you to look at the health science field from holistic and analytic perspectives to provide a basis for making sound personal health choices. You will examine the range of philosophies that guide health care and consider ethical decision within those contexts. Understanding the basic anatomy and physiology of the human body will provide a context for studying the normal and abnormal functioning of various body systems, including the role of nutrition and metabolism. You

will examine diagnostic tools and procedures and how they are used to inform treatment. You will investigate the range of health science careers and post-secondary programs available in Saskatchewan.

Text: Health Science

### **PHYSICAL SCIENCE 20**

Prerequisite: Science 10

This course combines chemistry and physics in an integrated manner to investigate concepts related to heating and cooling, the foundations of chemistry, including the mole and quantitative analysis of molecules and chemical reactions, and the characteristics and properties of waves. An overarching theme is the study of the enterprise of public and private science as it occurs in agriculture, industry, and universities to help you better understand various physical science related career paths. An inquiry project will guide your independent investigations of physical science phenomena.

### **ENVIRONMENTAL SCIENCE 20**

Prerequisite: Science 10

You will learn how to examine local and global environmental issues from a systems perspective while considering the effects of human actions and a growing global population on the climate and environment, as well as the effects of the environment on human health. You will explore the mechanisms and importance of aquatic and terrestrial ecosystems and the sustainability of past and current practices and technologies humans have developed to live with and within the environment.

Text: Environmental Science

### **BIOLOGY 30**

Prerequisite: Health Science 20 or Environmental Science 20

This course serves as an overview of internal living systems with an emphasis on humans. Study includes molecular biology, cells, heredity, human anatomy and physiology, and evolution. Skills are developed in investigation, drawing conclusions, distinguishing among observation, inference and conclusion, and research. Students develop an appreciation of the complexity and inter-relations of all living things. Students are required to do an independent research project.

### **AP BIOLOGY 30**

AP Biology is a course developed to prepare students for advanced study in life sciences at the post-secondary level. The topics covered in the course will include biochemistry, cellular biology, metabolism, genetics, molecular biology, evolution, biological classification, and ecology. In addition to this content, students who take AP Biology will develop advanced inquiry and reasoning skills, such as designing a plan for collecting data, analyzing data, applying mathematical models, and connecting concepts in and across domains.

Text: *Biology*, Miller & Levine

### **CHEMISTRY 30**

Prerequisites: Physical science 20

Students interested in a challenging course that will provide them opportunity to take engineering or other science related fields at the next level should consider taking this academic course at high school. Course content includes Student Directed Study, Chemical Bonding and Materials Science, Chemical Equilibrium and Electrochemistry.

### **AP CHEMISTRY 30**

The AP Chemistry course provides students with training for such knowledge and skills through guided inquiry labs, a focused curriculum on content relevant to today's problems, and an exam that assesses students' mental models of the particulate nature of matter instead of memorization of rules to understand chemistry.

Text: *Glencoe Chemistry: Matter and Change*, McGraw-Hill



**COMPUTER SCIENCE 20**

Prerequisite: Science 10

Computer Science 20 involves learning how to create, develop, and invent applications through a pragmatic approach. All students are recognized as beginners. The three elements that we focus on are Programming/algorithms, hardware and troubleshooting, and careers. Throughout the class, we use technology such as cell phones, tablets, and cloud computing for a paperless workplace and lab experience.

**COMPUTER SCIENCE 30**

Prerequisite: Computer Science 20

Computer Science 30 takes off where Computer Science 20 left in the previous semester. You will create, develop, and organize a major project of your choice. You will study more technical and advanced techniques in programming, method building, and algorithm design. You may also wish to extend your knowledge to robotics, design, etc. The choice is yours.

**PHYSICS 30**

Prerequisites: Physical science 20

This course covers aspects of motion, forces, energy momentum, electricity and magnetism. Students develop skills such as measurement, graphical analysis and problem solving as well as experimental methods.

**AP PHYSICS 30L/30**

The AP physics 1 course is spread over two one credit courses. In the first course the topics are; measurements, uncertainties & vectors, kinematics in 1 & 2 dimensions, dynamics in 1 & 2 dimensions, energy & momentum conservation in 1 & 2 dimensions, and circular motion. The second course topics are; simple harmonic motion & waves, electrostatics & electric circuits, rotational kinematics & dynamics, rotational energy & angular momentum.

Text: *Fundamentals of Physics: Combined Edition*, Heath

———— **SOCIAL STUDIES COURSES** ————

**NOTE:** French Immersion students must take Histoire 20 but may choose Native Studies 20, Geography 20, Psychology 20, or Law 30 as an elective.

**HISTORY 10**

Prerequisite: Complete Grade 9

This course is designed to help students understand the basic institutions of industrialized, democratic society. The history program uses the past to show students how fundamental social organizations developed in the late eighteenth and nineteenth centuries. Units include Political Decision-Making, Economic Decision-Making, Ideological Decision-Making, International Economic Relations and International Political Relations. Topics include the French Revolution, European Exploration and Imperialism.

**NATIVE STUDIES 10**

**Prerequisite: Complete Grade 9**

Native Studies 10 concentrates on positive images of First Nations, Métis and Inuit peoples. It allows students to develop their knowledge, and cultural understanding about First Nations, Métis and Inuit peoples, historically and contemporarily with heavy emphasis on traditional life. The unique history of Aboriginal peoples is part of our collective past and present reality. Thus, students will benefit from a study of Aboriginal peoples because it will give them the opportunity to understand and respect one another.

**TRADITIONAL WELNESS PURSUIT (2 course hours)****Prerequisite: Complete Grade 9 Social Studies and Physical Education**

This course has been specifically designed to allow Campbell students to achieve both a Social Science 10 credit and a Wellness 10 credit. Students will work within a framework that exposes them to traditional Indigenous cultures from around Saskatchewan. There is a specific focus on traditional living elements and outdoor pursuits, which includes tipi raising, fire building/cooking, horse-back riding, canoeing, etc. Students will also receive the health and physical education objects of wellness.

**HISTORY 20**

Prerequisite: a Grade 10 social science

The course examines major developments of the twentieth century and the impact they have had on relationships internationally, and on international political and economic affairs. Themes include World War I and the Russian Revolution, the Rise of Single Party States, World War II, the Cold War and the Sixties.

**NATIVE STUDIES 20****Prerequisite: Grade 10 social science**

The course is an examination of contemporary issues of concern to Indigenous peoples around the world. It is hoped that students will gain an understanding of the historical bases of current issues of concern to Indigenous peoples; become aware of and increase their understanding of philosophies which are the foundations of Indigenous cultures; and develop a personal sense of social commitment through the creation and implementation of action plans for social change.

**PSYCHOLOGY 20**

Prerequisite: any Grade 10 social science

This introductory course in psychology explores what psychology is and its application in individual, group and family relationships. The emphasis is on social psychology. Students will reflect on how we learn, solve problems, perceive, feel, and get along with others, and will be asked to apply psychological principles and theories to their own lives. Themes include identity, personality, gender, social development, and group Interaction.

**NOTE:** French Immersion students must take Histoire 20 but may choose psychology as an elective.

**PERFORMANCE PSYCHOLOGY 20**

The Performance Psychology 20 class provides students with the skills to achieve higher levels of excellence in their athletic, musical and dramatic pursuits. Students that are committed to performing at the highest possible level for themselves in sport or the performing arts will be able to immediately apply what they are learning in class to their preparation and performance outside of class. Units of study include such topics as theories of psychology, confidence, goal setting, building strong personal and relationship habits, achieving excellence, basic mental training skills, motivation, leadership, personality types and personal character development. Guest speakers from a variety of performance areas provide additional insights. The highlight of the semester is a one day outdoor activity field trip. This class will fit your graduation requirement for a grade 11 psychology social science elective.

**NOTE:** Students may choose psychology 20 or performance psychology 20 but not both.

**NOTE:** French Immersion students must take Histoire 20 but may choose performance psychology as an elective.

**HISTORY 30**

Prerequisite: a Grade 10 social science

This course studies past developments in Canadian history and examines how they have affected the political, economic, social and cultural conditions of Canada today. Areas covered include Aboriginal peoples and European colonization, the road to Confederation, French-English relations, Canadian-American relations, and the development of Canada during the 20<sup>th</sup> century.

**LAW 30**

This course introduces the student to basic elements of Canadian law, including origins of legal systems, and criminal, civil, tort, family and contract law. Students are encouraged to develop communication, participatory and analytical skills through the use of debate, discussion and case study. Units include the Rule of Law, How Canada's Laws Are Made, Categories of Law, Human Rights, Criminal Law, Bringing the Accused to Trial, the Court, and Sentencing, Appeals and Prison.

**NATIVE STUDIES 30**

Prerequisite: A Grade 10 social science

Native Studies 30 is based on the premise that distinct perspectives are common, that diversity of truths exists, and that the motivation for most behaviours and attitudes may be traced to the worldviews and philosophical orientations of people. The purpose of this curriculum is not to attempt to articulate the precise Aboriginal values and beliefs which shape worldview and philosophy, but rather to stress their importance for gaining insight into the Aboriginal people of Canada. Themes include: Aboriginal and Treaty Rights, Governance, Land Claims and Treaty Land Entitlements, Economic Development and Social Development.

**PSYCHOLOGY 30**

Prerequisite: Psychology 20 recommended

This senior course in Psychology builds on the content of Psychology 20. The focus is on Human Development across the Life Span, especially as it relates to the family and our growth as humans. Areas of study include Bio-Psychology, Personality Development, Cognitive Development and Social Development.

———— **FINE ARTS COURSES** ————

*The following music classes are offered on the regular timetable.*

**MUSIC 10 GUITAR\***

Prerequisite: None

The objectives of Guitar 10 will be the familiarization of the instrument, the basic music theory involved combined with an emphasis on skill development. Students will learn the various parts of the guitar, methods of playing, musical forms, and basic music theory including chord building, traditional notation and tablature. All students will get the opportunity to learn music from a wide variety of genres and styles. Students are expected to demonstrate great care and respect for both the instruments and others in the class. Students will be evaluated on participation, attendance, attitude, playing exams, as well as progress in skill development.

**MUSIC 20 GUITAR\***

Prerequisite: Guitar 10L

Students will continue to become familiar with the instrument. This will include a focus on music theory and further skill development. Topics covered will include advanced methods of playing, sight reading of traditional notation as well as tablature, musical forms as well as musical theory. All students will get the opportunity to learn music from a wide variety of genres and styles. Students are expected to demonstrate great care and respect for both the instruments and others in the class. Students will be evaluated on participation, attendance, attitude, playing exams, written exams as well as progress in skill development.

**MUSIC 30 GUITAR\***

Prerequisite: Guitar 20L

Students will continue to become familiar with the instrument. This will include a focus on music theory and further skill development. Topics covered will include advanced methods of playing, sight reading of traditional notation as well as tablature, musical forms as well as musical theory. The opportunity for students to be broken down into duets, trios and other small ensembles will be the focus for a large part of the semester. Public performance of these ensembles will be a mandatory aspect of the class. Students are expected to demonstrate great care and respect for both the instruments and others in the class.

Students will be evaluated on participation, attendance, attitude, playing exams, written exams as well as progress in skill development.

**MUSIC/INSTRUMENTAL 10, 20 & 30**

Prerequisites: Previous level of Music/Instrumental, or permission of instructor (based on previous experience with a concert band instrument through a community band, private lessons or school classes)

The Music/Instrumental courses focus on developing technical skills, sight-reading ability and ensemble playing. Each level completes graded theory requirements and, through selected listening opportunities, students learn to distinguish and appreciate music of different periods and styles. Composition and Jazz improvisation may be offered, depending upon the interest and skill of those students enrolled. Students must also join Noon Band as a co-requisite for an additional credit.

Texts: *Foundations for Superior Performance Through Band; I Recommend, Master Theory, Books I-V; 14 Weeks To A Better Band; A Treasury of Scales*

**ORCHESTRA 10L/20L/30L**

Prerequisite: experience with a STRING instrument – violin, viola, cello, string bass, and concert harp

This is an ensemble performance class which will provide students with the opportunity to continue an intensive study of literature in both the string and orchestral idioms in the public school setting.

The class will focus on sight-reading, technical skill development, and an appreciation of ensemble with respect to dynamics, tone, balance and intonation through an exploration of both traditional and modern repertoire.

Students will be involved in 3 public performances over the course of the year and will also be given the opportunity to hear live orchestral performances.

**MUSIC 10/20/30 MUSICAL THEATRE\***

Prerequisite: None

This class is an exciting opportunity for all Campbell students who enjoy singing, acting and stage production to learn more about these areas in a comfortable, high-quality atmosphere! Students will have the opportunity to perform and participate in a variety of musical theatre activities that include a major musical theatre production. Participation in this performance based course helps to foster a great amount of musical and personal growth in each class member.

*Students in this class should also join Noon Choir for an extra credit.*

*Students in this class are also invited to audition for a vocal jazz ensemble!*

***The following classes are offered as off timetable courses:***

**INTERMEDIATE BAND 10 (NOON BAND 10)\***

Pre-requisite: Previous level of Noon Band or permission of the instructor (based on experience with a concert band instrument through a community band, private lessons, or school classes)

Rehearsals are held twice weekly during the noon hour. Membership extends from September through early June. Members of the Intermediate Band are invited to audition for jazz bands. Participation and attendance at all rehearsals, concerts and festivals is mandatory.

**SENIOR BAND (NOON BAND 20/30)\***

Pre-requisite: Previous level of Concert Band or permission of the instructor (based on experience with a concert band instrument through a community band, private lessons, or school classes)

Rehearsals are held twice weekly. Membership extends from September through early June. Members of the Senior Band are invited to audition for jazz bands. Participation and attendance at all rehearsals, concerts and festivals is mandatory.

**INTERMEDIATE VOICES (NOON CHORAL 10)\***

Prerequisite: None

If you love to sing, or are interested in singing, then this group is for you!! The Campbell Intermediate Voices is a high-energy ensemble that performs a variety of quality choral repertoire. The Intermediate Voices is a noon hour class held on Tuesdays and Fridays at lunch. Dedication to developing and maintaining high standards of musicianship and performance are emphasized. The Intermediate Voices focus on a variety of choral repertoire that is interesting, enjoyable and challenging. Participation in this ensemble helps to foster a great amount of musical growth in each choir member. Campbell Choirs are nationally recognized for their emphasis on the performance of quality choral repertoire. Students from this class are invited to audition for the Chamber Choir and the Vocal Jazz Ensembles. Participation and attendance at all rehearsals, concerts and festivals is mandatory.

**SENIOR VOICES (NOON CHORAL 20/30) \***

Prerequisite: Noon Choir 10 recommended

The Campbell Senior Voices is a high-energy ensemble that performs a variety of quality choral repertoire. The Senior Voices is a noon hour class held on Tuesday and Friday's at lunch. Dedication to developing and maintaining high standards of musicianship and performance are emphasized. The Senior Voices focus on a variety of choral repertoire that is interesting, enjoyable and challenging. Participation in this ensemble helps to foster a great amount of musical growth in each choir member. . Campbell Choirs are nationally recognized for their emphasis on the performance of quality choral repertoire. Students from this class are invited to audition for the Chamber Choir and the Vocal Jazz Ensembles. Participation and attendance at all rehearsals, concerts and festivals is mandatory.

**VOCAL JAZZ 10, 20 & 30 (VJ1 or VJ2)**

Co-requisite: Noon Choir 10, 20 or 30

These ensembles provide Campbell students who are interested in exploring jazz the opportunity to participate in high quality, high-energy performing vocal jazz ensembles. These ensembles are nationally recognized for their performance of quality repertoire in a variety of jazz styles. Attendance at all rehearsals, concerts, and festivals is mandatory.

**INSTRUMENTAL JAZZ 10, 20 & 30**

Co-requisite: Noon Band 10, 20, 30

Students receive one credit at the appropriate grade level.

Students become familiar with the standard jazz ensemble literature, its famous performers (current and historical), definitive style traits, basic jazz theory, as well as important recordings. As instrumental skills develop, opportunities for improvisation will be offered. Students have opportunities to respond critically to both recorded and live performances (including their own).

Texts: *The Goal Note Method*, *Peters for Improvisation*, *Frank Mantooth Jazz series*, *The Real Easy Book*.

**Note: AP Music 20/30 is also offered. For more information about this course, please contact Mr. Peters**

\*\*\*\*\*

**VISUAL ART 10\***

Students are encouraged to apply their knowledge of the elements of art and principles of design to their own work and discussions. As in previous years they explore ideas, materials, tools and techniques in order to present their ideas in a personal way. Students are evaluated on participation, attitude, attendance, projects and exams.

The cultural/historical (examination of art and artists from a variety of periods and cultures) creative/productive (making of art) and critical/responsive (analysis and criticism of one's own and others' art) components of the Arts Education curriculum are fundamental to the instruction of this course.

**VISUAL ART 20\***

Visual Art 20 is a continuation of the grade 10 program. As in previous years, the students explore ideas, materials, tools, techniques and present their ideas in a personal way (creative/productive). Discussion and analysis of artists' works are used to further develop students' skills and knowledge (critical/responsive). An understanding of various artists, artistic styles and cultures is encouraged through research, discussion and community/gallery visits (cultural/ historical).

**VISUAL ART 30\***

Students in Grade 12 explore a variety of arts expressions through the creative/productive, cultural/ historical, and critical/responsive components of Arts Education. They increase their understanding of the languages and creative processes of visual art and convey their own ideas using a variety of materials, tools and techniques. An in-depth understanding of various artists, artistic styles and cultures is encouraged through discussion, research, and community/gallery visits. Throughout the class, students are challenged to interpret and analyze art works based on content found in the work.

**AP VISUAL ART**

For Inquiries about AP Visual Art, please see the teacher, Mrs. Marchtaler.

In grade 11 students will need to take Visual Art 20 and Painting and Drawing 20 (if their focus is going to be on 2 D media) or Sculpture 20 (if their focus is going to be 3 dimensional media). The focus of this year is the breadth of media and mainly teacher directed assignments – more than 12 need to be created by the end of the year to be added to their Breadth portfolio.

In grade 12 students will need to take Visual Art 30 and Painting and Drawing 30 (if their focus has been 2D) or Sculpture 30 (if their focus has been 3D). The focus of this year is on their concentration (theme) and will be more student driven. They will need more than 12 pieces by the end of this year to complete the concentration part of their portfolio.

During the month of May pieces will be chosen for each portfolio and uploaded. If student's feel some pieces for their breadth portfolio are weak, students can go into work they did in the grade 10 year to fill the spots. 5 pieces from the 24+ piece portfolio that show great quality in technical skill will be physically sent to the AP board for examination.

**VISUAL ART SPECIALIZATIONS**

Drawing and Painting 20/30L and Sculpture 20/30L, are offered for students interested in specializing their art studies. The cultural/historical, creative/productive, and critical/responsive components of the Arts Education curriculum are fundamental to the instruction of these courses.

**ART 20L DRAWING/PAINTING OR ART 20L SCULPTURE \***

Emphasis is on skill development and a variety of two-dimensional media or three-dimensional art forms. In addition, there are gallery visits, the study of local artists and personal research.

**ART 30L DRAWING/PAINTING OR ART 30L SCULPTURE\***

These courses are recommended for more serious art students. Individual artistic growth will be encouraged through skill development, gallery visits, and the study of local and international artists, personal research and portfolio building.

**———— PHYSICAL EDUCATION, HEALTH AND WELLNESS COURSES ————****WELLNESS 10**

Prerequisite: Complete Grade 9

The Wellness program is a blend of Health and Physical Education. The course will be gender segregated. It incorporates the components of fitness into practical applications. Fitness assessments will be done throughout the semester in order to encourage students to develop good decision making skills and a healthy lifestyle. The program is diverse in that students will

experience activities which they may wish to continue in the future. Students have the opportunity to participate in both team and individual lifelong pursuits.

Nutrition, healthy eating, HIV/AIDS education, family life education and healthy relationships are topics of discussion.

Volunteerism in both school and/or community is a required portion of this class.

### **PHYSICAL EDUCATION 20 (COED)\***

Prerequisite: Wellness 10

The grade eleven Physical Education Program focuses on lifelong recreational activities that are available in our community. Students will be given the opportunity to learn and develop the skills needed to participate in these activities. Bus transportation to the different venues will be provided. Students will also focus on their own personal fitness development by developing a greater understanding of the Health Related Components of Fitness. Fitness assessment will be done throughout the semester so students have the opportunity to monitor their progress.

Activities: Water Polo, Snorkeling, Gymnastics, Tennis, Curling, Five-pin Bowling, Ten-pin Bowling, Wallyball, Level 10, Spin Class, Group Kick Class, Boxing, Racquetball, Volleyball, Basketball, Badminton, Tchoukball, Football, Soccer. A downhill ski/snowboard trip with other credit physical education classes will be available. This will be an extra cost and will be optional.

### **PERSONAL FITNESS 20L/30L**

This class is going to focus on training the human body for various performance needs. The training will consist of weight lifting (hypertrophy, strength, power, toning), speed, agility, cardio, bosu, TheraBall and body weight exercises. We will also cover action planning, setting personal fitness goals, anatomy and nutrition education (pre workout, post workout, daily needs) Anyone looking to increase their physical performance in a given sport (both in and out of season), become healthier overall and push their body to a level that they have not reached before should consider taking this class. **It will be offered in the morning before 8:30 classes begin and it will run in both semesters if enrollment permits.**

### **PHYSICAL EDUCATION 30 (COED)\***

This program includes some new activities plus some activity repetition from the Physical Education 20 course. Students will be directed toward a higher level of skill acquisition and knowledge with the activities being covered. Students will focus on their own personal fitness development by developing a high understanding of the Health Related Fitness Components. Fitness assessment will be done throughout the semester so students have the opportunity to monitor their progress.

Activities: Golf, Tennis, Curling, Ten Pin Bowling, Boxing, Billiards, Squash, Scuba Diving, Level 10, Spin Class, Group Kick Class, Wallyball, Water Polo, Gymnastics, Tchoukball, Volleyball, Basketball, Badminton, Football, Soccer. A downhill ski/snowboard trip with other credit physical education classes will be available. This will be an extra cost and will be optional.

### **OUTDOOR PURSUITS 20/30:**

The goal of this course is to develop an appetite for lifelong learning in an outdoor setting. Through a variety of outdoor activities and skill development, we hope that you will find success and inspiration that will become a part of your current and future lifestyle. Outdoor activities may include cross-country skiing, snowshoeing, downhill skiing/snowboarding, canoeing, kayaking, mountain biking, archery, hiking, geocaching, GPS, map and compass use, and/or winter and spring camping. The Outdoor Technical Skills that are covered will include outdoor living skills, fire building, clothing and gear preparation, animal safety, equipment maintenance, First-Aid and survival skills. The Life Skills covered in this class will include teamwork and problem-solving, using effective communication skills, physical fitness development, goal-setting, commitment, mental toughness, nutritional planning and outdoor applications, "leave no trace", trip planning and budgeting.

\*\*This class will include 2-3 weekend outdoor experiences throughout the semester. These trips will cover important curricular topics and will not affect your incentive in other classes. Time off of our class will be given in lieu, so students can get caught up on missed content in other classes. Approximately 3 school days will be missed throughout the semester.

\*\*These outdoor trips will cost approximately \$200 in excess of the regular course fee.

———— **PRACTICAL & APPLIED ARTS COURSES** ————

**ACCOUNTING 10\***

Students learn the basic financial statements and the simplified accounting cycle for a small service business in detail. They will examine the concepts of Generally Accepted Accounting Principles (GAAPs) and apply these concepts within the accounting activities. Upon completion of this course, students will have obtained the bookkeeping skills required in the operation of a small service company. A brief study of careers in accounting and the professional bodies of CA's, CMA's and CGA's are included. Students will also do personal finance activities such as creating a personal budget. Evaluation is based on projects, assignments, tests and professional business work ethic.

**ACCOUNTING 20\***

Prerequisite: Accounting 10

Students will examine the accounting cycle for a medium sized merchandising business, organized as a partnership. They are introduced to the Simply Accounting software package and the bookkeeping applications are all computer based. Students will study adjustments and use special journals in the accounts receivable, accounts payable, inventory and banking applications. The recording of taxes (provincial sales and GST) are introduced and the concepts of the GAAPs continue to be applied. A short unit on taxes and filing tax returns is also covered. Evaluation is based on projects, assignments, tests, simulations and professional business work ethic.

**ACCOUNTING 30\***

Prerequisite: Accounting 20

Students in Accounting 30 will examine the new accounts and procedures associated with corporate accounting for a merchandising firm. The use of Simply Accounting is continued as all application problems are computer based. They will study the cost of goods sold, depreciation, accruals and payroll. Content covered will provide students with the opportunity to think about how managers make decisions and will give students opportunities to look at the relationships between costs and business activity. Taxes will be reviewed and auditing will be covered. This class may audit the Entrepreneurship 30 class ventures. Evaluation is based on projects, assignments, tests, simulations and professional business work ethic.

**BUSINESS & SOCIAL TECHNOLOGY 10 (Information Processing 10)**

The focus of this computer-based course is to facilitate the development of students as 21<sup>st</sup> century learners. Students will have the opportunity to CREATE, COLLABORATE, and COMMUNICATE as they develop a variety of key employability skills. The goal of **Business and Social Technology 10** is to develop students' preparedness to be successful citizens in their own lives and the business world. Students preparing for all types of adult responsibilities require a sound understanding of how to create, access, use and manage business and social technology. Students will develop valuable skills as they explore the areas of: technology fundamentals, social media, word processing, effective presentations, communication and spreadsheets.

**BUSINESS & SOCIAL TECHNOLOGY 20 (Information Processing 20)**

The focus of this computer-based course is to further the development of students as 21<sup>st</sup> century learners from their experience in Business and Social Technology 10. Students will have the opportunity to CREATE, COLLABORATE, and COMMUNICATE as they expand on a variety of key employability skills necessary for the future. The goal of Business and Social Technology 20 is to further the student's understanding in presenting, creating, and organizing information with a focus on the business world. Students preparing for all types of adult responsibilities require a sound understanding of how to create, access, use and manage business and social technology. Students will develop valuable skills as they explore the areas of: intermediate technology skills, social media for business, intermediate word processing, advanced presentation skills, intermediate business communication and advanced spreadsheets.

**BUSINESS & SOCIAL TECHNOLOGY 30 (Information Processing 30)**

The focus of this computer-based course is to facilitate the advanced development of students as 21<sup>st</sup> century critical and creative thinkers. Students will have the opportunity to CREATE, COLLABORATE, and COMMUNICATE as they develop a variety of key employability skills. The goal of Business and Social Technology 30 is to further develop a variety of skills in areas such as: social media, word processing, spreadsheets, effective presentations, advertising, communication and business strategy.



**ENTREPRENEURSHIP 30**

Prerequisite: None

The goal of Entrepreneurship Education is to learn skills and information needed to establish and run a small business. This course will help students learn problem solving, communication and analytical skills while determining potential opportunities. Students will look at societal problems and/or needs with an eye for creating change in order to seek and explore, and take advantage of opportunities that exist everywhere! Units covered include Characteristics and Attitudes of an Entrepreneur, Opportunity Assessment, The Business Plan, Marketing, Operation and Financial Planning. Students will participate in the Junior Achievement Company Program where they will plan, finance, create and run their own class company. Evaluation is based on assignments and projects.

**PERSONAL FINANCE 30L**

With credit card debt, household debt, and national debt becoming alarming issues both in Canada and around the world, many people ask where personal finance is being taught. Until now, it has not been taught and many youth and adults with poor financial literacy have been making crucial mistakes with their finances. Personal Finance 30L is the most important class that you can take during your high school career as no matter what your future holds, you will need to be financially literate. Topics covered in this course include: Economics, Decision Making and Money Basics, Banking Services, Income and Taxation, Budgeting, Savings and Investing, Credit and Credit Cards, Consumer Protection, and Renting, Leasing, and Buying. Take Personal Finance 30L and work towards becoming an informed, financially literate member of society through a practical, hands-on learning experience.

**COMMUNICATION MEDIA 10\***

Communication Media 10 introduces students to basic knowledge skills and abilities in audio, video and interactive media. Students are introduced to aspects of video production including production stages, lighting, use and care of audio/video equipment and planning of projects. The importance of audio in isolation is introduced, as well as audio editing software. Creation of interactive media, such as web pages, to communicate effectively, is introduced.

There is a materials fee to take this course.

**COMMUNICATION MEDIA 20\***

The use of digital video cameras, computers as non-linear editing tools, digitization of analog sources, use of associated computer software, and the production of digital material will be discussed. Multiple camera techniques and studio lighting are covered as well. Audio production and post-production techniques are investigated, as well as interactive media. Students continue to build a working portfolio with the goal of producing a showcase portfolio. Involvement in the production of promotional items for school groups and activities is an expectation.

There is a materials fee to take this course.

**COMMUNICATION MEDIA 30\***

Students at this level produce a showcase portfolio that demonstrates their abilities in audio, video and interactive media. Students have four project options available. In each case the projects require 100 hours of production time, appropriate use of a project log and the completion of a showcase portfolio on a variety of media. Students must adhere to a production schedule. The final mark is derived from evaluation of the project log, showcase portfolio, project presentation and adherence to the production schedules. There is a materials fee to take this course.

**CONSTRUCTION AND CARPENTRY 10 (Woodwork)\***

Prerequisite: None

Students will be learning shop safety, measurement, basic power tool use, basic hand tool use, basic joinery, and basic finishing techniques. These are taught through the construction of two or three projects (time depending). There is a large emphasis on safety and accuracy of work. Students will be required to work independently and in groups. Students are encouraged to wear work clothes but are not required. There is a fee for materials and shop supplies used.

**CONSTRUCTION AND CARPENTRY 20 (Woodwork)\***

Prerequisite: Construction and Carpentry 10

Construction 20 builds on the techniques taught in Construction 10. Students will build one or two intermediate skilled projects. Safe and accurate work is a requirement of the course. Students are encouraged to wear work clothes but are not required. There is a fee for materials and shop supplies used.

**CONSTRUCTION 30 (Woodwork)\***

Prerequisite: Construction and Carpentry 20

Construction 30 builds on the techniques taught in Construction 20. Students will build an advanced project. Safe and accurate work is a requirement of the course. Students are encouraged to wear work clothes but are not required. There is a fee for materials and shop supplies used.

**DESIGN STUDIES**

Design Studies highlights the techniques and methods for developing innovative and useful ideas for business, engineering, fine arts, and for personal use. The student as designer explores possibilities for creating, refining or adapting objects and the selection of appropriate materials and resources. Students work in two and three dimensional designs and consider the business/career aspects of pure design. Options include work experiences, modeling and prototype fabrication, learning Professional CAD software.

**DESIGN STUDIES 10\***

Prerequisite: None

Design 10 introduces students to Design Fundamentals, and how to manipulate and apply these in a variety of team and individual problem solving situations. Early modules will be basic assignments and design problem briefs, building towards more complex design challenges. Autodesk design software is introduced as an integral design tool.

**DESIGN STUDIES 20\***

Prerequisite: Design 10 is recommended, or permission of the instructor.

Building upon the fundamentals of Design 10, 20 level Design Studies will develop individualized assignment and opportunities for independent initiatives, while re-enforcing the importance of collaboration and team solutions. Students explore more complex two and three dimensional design problems within both a physical and computer generated context.

**DRAFTING AND CAD 10\***

Prerequisite: None

Drafting 10 develops skills in mastering computer assisted drafting. Students will work on various projects using computer assisted drafting that increase in complexity. Students will develop the skills of viewing two dimensional and three dimensional drawings. The course will conclude with the students drawing the plans of a small cottage. This class provides a strong background for students entering into Engineering, Architecture, Design and CAD Drafting.

**DRAFTING AND CAD 20\***

Prerequisite: Drafting 10

Drafting 20 develops skills in mastering residential construction. Students will explore all aspects of house construction from the foundation to the roof details. Students can further develop their skills in computer assisted drafting by producing projects involving site plans, floor plans, views and sectionals. Several tours will be taken to residential construction sites to further develop the students three dimensional experience. Students will conclude the semester withdrawing their own house plans with a complete set of building drawings. The class provides a strong background for students entering into Engineering, Architecture, Design and CAD Drafting.

**DRAFTING AND CAD 30\***

Prerequisite: Drafting 20

Drafting 30 will further develop the students' skills in three dimensional designs. Projects will include residential and commercial construction. The class provides a strong background for students entering into Engineering, Architecture, Design and CAD Drafting.

**FOUNDATIONS OF ENGINEERING SYSTEMS & TECHNOLOGY: ROBOTICS (ENGG & TECH)**

Robotics is the science and technology of robots, their design, manufacture, and application. We are in partnership with the University of Regina's Faculty of Engineering and Applied Science to provide the best of instruction and components. This design changes yearly with the Skill Canada Robotics Competition. You have a chance to compete in the world competition that is held around the globe. Be the best and challenge yourself while learning real life engineering techniques and concepts in a creative, cooperative and supportive environment. (One after-school class per week)

**ENGINEERING ROBOTICS 10\***

Prerequisite: None

Students will be learning the essential skills to be successful in Robotics in later years. Skills will include working with Electronics, Design Studies, Drafting, and Engineering Career Modules. Students will also engage in problem solving when working on small and large projects. The projects built will have the opportunity to participate in class competitions to challenge their designs against other peers. Engineering Robotics 10 students could qualify for Engineering Robotics 20 and 30 level courses.

**ENGINEERING ROBOTICS 20\***

Prerequisite: None

You will be working in teams providing mentorship and expert knowledge with the new Eng. & Tech 10 teams. You will be building and competing in competitions with the added confidence of the previous year. The problem solving skills, engineering techniques and bonus technology skills learned will give you the street credibility for better jobs and a great asset to universities across the country! (One after-school class per week)

**ENGINEERING ROBOTICS 30\***

Prerequisite: None

You will be working in teams providing mentorship and expert knowledge with the new Eng. & Tech 10 & 20 teams. You will be building and competing in competitions with the added confidence of the previous year. The problem solving skills, engineering techniques and bonus technology skills learned will give you the street credibility for better jobs and a great asset to universities across the country! (One after-school class per week)

**PHOTOGRAPHY 10\***

Prerequisite: none

Photography 10 highlights the use and integration of industry standard applications and techniques in the field of Graphic Design and Digital Photography. Emphasis on problem solving complex layouts, the role of business advertising, digital media and manipulation will be addressed. Photography, both digital and film, and image editing techniques will be introduced.

**GRAPHIC ARTS 20\***

Prerequisite: Photography 10 OR Graphic Arts 10 (when offered).

Students taking Graphic Arts 20 will build upon their knowledge of digital photography and image manipulation as introduced at the 10 level, and will explore the printing process, including artists' use and understanding of colour, in greater depth. Exploration of advertising and packaging will also be emphasized. .

**GRAPHICS ARTS 30\***

Prerequisite: Graphic Arts 20 or permission of the instructor

Graphic Arts 30 builds upon the skills used in the graphic arts and design industries as acquired at the 20 level. Students create real world projects in the areas of photography, design/layout, typography and marketing/packaging, and work towards independent projects, culminating in a web-based portfolio showcase.

**GRAPHIC ARTS 20/30 YEARBOOK\*:**

The Graphic Arts 20/30 (Yearbook- off timetable) class covers the same concepts as the regular Graphic Arts 20/30, with a focus on the production of the school's Yearbook. Students will work with elements and principles of design, layout, typography, colour, photography, concept development and project production all as it relates to a Yearbook publication. The class will take place twice per week after school over the course of both semesters.

**COMMERCIAL COOKING 10\*:**

Prerequisite: None

The aim of commercial cooking 10 is to provide students with the knowledge and skills necessary for entry level skills in the food service industry. Emphasis will be placed on kitchen safety and sanitation, terminology and fundamental practices related to cooking and employability skills.

**FOOD STUDIES 30\***

Prerequisite: None

This course provides an in-depth study about food. Topics include nutrition and wellness as they relate to food choices, food preparation, cultural foods, meal planning and a healthy diet. An 8 hour food safety certification course has been incorporated into the course.

**PAA SURVEY A 20 CUISINE\***

Prerequisite: None

In this 20 level course students will expand on the skills learned in Commercial Cooking 10. The focus will be on introduction to garde manger and soup stations in a professional kitchen. Students will gain experience in prepping sandwiches, salads, hour d'oeuvres, stocks, sauces and soups.

**PAA SURVEY A30 BAKING\*:**

Prerequisite: None

The aim of this course is to build basic skills in the area of pastry and baking. Students will become comfortable with the tools and equipment used in the bakeshop and prepare a variety of doughs and batters both sweet and savoury.

**AUTO-MECHANICS 10\***

No prerequisite

Mechanics 10 focuses on three main units: Brakes, Small motors, and Vehicle maintenance. There is a strong emphasis on hands on work in the auto shop. Students will be required to have proper clothing (Coveralls or work cloths). In the shop safe work habits are encouraged, as well as accuracy for the work being done.

**AUTO-MECHANICS 20\***

Prerequisite: Auto 10

Mechanics 20 builds on the knowledge gained in Mechanics 10. Students will be able to work on their own vehicles if the work fits into the units being covered in class. Students are not required to have their own vehicle, a vehicle will be provided to be worked on. Students will be required to have proper clothing (Coveralls and work cloths). There is strong emphasis on group work and accuracy of work.

**AUTO-MECHANICS 30\***

Prerequisite: Mechanics 20

Mechanics 30 builds on the knowledge gained in Mechanics 20. Students will be able to work on their own vehicles if the work fits into the units being covered in class. Students are not required to have their own vehicle, a vehicle will be provided to be worked on. Students will be doing more in depth procedures (Ex: Cylinder heads, timing belts). Students will be required to have proper clothing (Coveralls and work cloths). There is strong emphasis on group work and accuracy of work.

**WELDING 10\***

Prerequisite: None

The objective of Welding 10 is to develop familiarity with the terms, tools, equipment and techniques of welding. Safety and the proper use of welding tools, materials and equipment are a priority in this class. Students learn the care of welding tools and equipment. Students will be exposed to Oxy/acetylene cutting, Oxy/acetylene, MIG and Arc welding. Students will have opportunity to practice and develop skills in these areas.

**WELDING 20\***

Prerequisite: Welding 10

Students in Welding 20 will review the concepts learned in Welding 10. Students will continue to develop and expand skills in Oxy/acetylene cutting, Oxy/acetylene, MIG and Arc welding. Welding 20 students begin to weld in vertical and horizontal positions, learn to set up a welding work station and use evaluation skills to judge welding workmanship.

**WELDING A30\***

Prerequisite: Welding 20

The Welding A30 course will further develop the welding shop skills acquired in Welding 10 and 20. There will be development of sheet metal welding and fabrication as well as a focus on project-based welding. The class will also continue the study of math applied to real world situations.

**WELDING B30\***

Prerequisite: Welding A30

Welding B30 continues to perfect welding skills through the fabrication and construction of welding based projects. TIG welding will be introduced at this level as well as welding aluminum.

**—LANGUAGES COURSES—****CORE FRENCH 10**

French 10 balances oral and written French equally and is based on a thematic communicative/experiential approach. This course emphasizes the concurrent development of oral communication, reading, and writing skills, using a broad-based theme such as travel. Students will be expected to use their growing French vocabulary to create presentations, answer basic questions, and generate conversations with their classmates. The use of language games, apps, music and movies make learning a language fun! Students will be introduced to new verb tenses and will expand on their previous vocabulary and grammar skills.

**CORE FRENCH 20**

Prerequisite: Core French 10

French 20 balances oral and written French equally and is based on a thematic communicative/experiential approach. This course enables students to practice spoken French in communicative situations and puts more emphasis on creating and sustaining conversations with peers. The principle broad-based theme of study is treasures and memories. We publish our very own children books and read them to an audience. Another project consists of assembling a timeline which includes some highlights of childhood, favourite activities, toys, a memorable moment and family celebrations and traditions. The use of language games, apps, music and movies make learning a language fun! Throughout the semester students will be introduced to new verb tenses and will expand on their previous vocabulary and grammar skills.

**CORE FRENCH 30**

Prerequisite: Core French 20

French 30 balances oral and written French equally and is based on a thematic communicative/experiential approach. This course enables students to practice spoken French in communicative situations and puts more emphasis on creating and sustaining conversations with peers. The principle broad-based theme of study is film. We produce our very own short film and celebrate the completed projects at a film festival. The use of language games, apps, music and movies make learning a language fun! Throughout the semester students will be introduced to new verb tenses and will expand on their previous vocabulary and grammar skills.

### **SPANISH 10**

This course is an introduction to the Spanish language and culture. It is organized around five themes: Family, Self, School, Music and food. While students work through these themes, they will be developing speaking, listening, reading and writing skills. The language will be practiced through interactive activities and presentations. The use of language games, apps, music and movies make learning a language fun and engaging! Grammar will be introduced as necessary to complete the activities. Students will learn greetings, numbers, describing self and family members, daily schedules and activities, birthdays and age, describing likes and dislikes, and expressing themselves in the present and future tense.

### **SPANISH 20**

Prerequisite: Spanish 10

This course is a follow-up to Spanish 10. Students will continue to build on vocabulary and skills learned in Spanish 10. It is organized around five themes: Body, Fashion / Clothing, Daily Activities, Health, Travel, and Consumerism. While students work through these themes, they will continue to develop speaking, listening, reading and writing skills. The use of language games, apps, music and movies make learning a language fun and engaging! The language will be practiced through interactive activities and presentations. Grammar will be introduced as necessary to complete the activities. We start in the past tense focusing on communicating.

### **SPANISH 30**

Prerequisite: Spanish 20

Students at this level will continue to build on vocabulary and other skills learned in Spanish 20. While students work through a variety of themes, they will be developing a higher level of speaking, listening, reading and writing skills. The Spanish language will be practiced through interactive activities and presentations. The use of language games, apps, music and movies make learning a language fun and engaging! To enhance our program, we will also take a close look at the lifestyle of many Latin cultures.

## ----- FRENCH IMMERSION COURSES -----

### **FRANÇAIS IMMERSION 10**

Prerequisite: Français 9

Listening, speaking, reading and writing are emphasized. The course is divided into composition/literature and grammar. The literature includes the print media, short stories and literary songs. Grammar includes present, past, future and conditional tenses, irregular verbs, pronouns, introduction to the subjunctive, adjective formation and gender. Students are required to deliver a speech in French.

### **FRANÇAIS IMMERSION 20**

Prerequisite: Français 10

Emphasizing listening, speaking, reading and writing, the course is divided into literature and grammar. Literature studied includes the novel, electronic media and comics, or *photo-romans*. Grammar study covers literary tenses, levels of language and an intensive review of grammar rules. Students are required to deliver a speech in French.

### **FRANÇAIS IMMERSION 30**

**Prerequisite: Français 20**

Français 30 will further develop listening, speaking, reading and writing through the study of literature, grammar, oral discussion and composition. During this integrated course, students will also reflect on the experience of learning in another language, French language speaking countries and cultures in the world, and imagine an ideal about bilingual identities in Canada.

### **AP FRENCH LANGUAGE AND CULTURE (FRANÇAIS IMMERSION 30)**

AP French Language and Culture is a course designed as a culmination of students' French studies in high school. At this point, they have already learned the structures necessary to communicate in French. In AP French, students review and refine those grammatical structures while learning new vocabulary to communicate in French on a variety of topics. AP French emphasizes all aspects of language: listening, speaking, reading, writing and culture. This course is designed to prepare students for the AP French Language and Culture examination. AP French Language and Culture is conducted exclusively in French.

### **SCIENCE SOCIALES 30**

Prerequisite: Histoire 10

Social Studies 30 will study past developments in Canadian history and examine how they have affected the political, economic, social and cultural conditions of Canada today. Areas covered include Aboriginal peoples and European colonization, the road to Confederation, French-English relations, Canadian-American relations and the development of Canada during the 20th century.

## ----- FRENCH IMMERSION ELECTIVES -----

### **FRANÇAIS IMMERSION INTÉGRÉ A 20**

Prerequisite: Français 10

This course focuses on the development of oral, written and listening skills. The language is experienced through two units. A cinema unit includes a study of the cultural dimension of film and its impact on our perception of the world. Students are introduced to the Entrepreneurship. This unit allows students to develop a better understanding of Business ideas and creation. The goal is to give students an opportunity to practice and improve their oral and written French.

### **LA CONSTRUCTION 10** (Construction/ bike technology)

This course will explore the use of skills, tools and techniques used in the construction of bamboo bicycles. Students will develop design strategies to create a blueprint of their bike frame as well as planning and implementing the build project. Students will be learning shop safety, measurement, basic power tool use, basic hand tool use, basic joinery, and basic finishing techniques to build a bamboo bicycle and install component parts. Students will be working in groups and individually.

## ----- MATHÉMATIQUES -----

**\*\* Please refer to the math pathway flowchart on page 3 for more information.**

### **MILIEU DE TRAVAIL 10**

Prerequisite: Complete Grade 9

This pathway is designed to provide students with the Mathematical understandings and critical-thinking skills identified for entry into the majority of trades and for direct entry into the work force.

### **FONDEMENTS DES MATHÉMATIQUES ET PRÉ-CALCUL 10**

Prerequisite: Complete Grade 9

**Fondements des mathématiques** – This pathway is designed to provide students with the mathematical understandings and critical-thinking skills identified for post-secondary studies in programs that do not require the study of theoretical calculus.

**Précalcul** – This pathway is designed to provide students with the mathematical understandings and critical-thinking skills identified for entry into post-secondary programs that require the study of theoretical calculus.

### **FONDEMENTS DES MATHÉMATIQUES 20**

Prerequisite: Fondements des mathématiques et pré-cal 10

The topics include inductive and deductive reasoning, properties of angles and triangles, triangle trigonometry, statistical reasoning; systems of linear inequalities, quadratic functions and equations, and proportional reasoning. Students who

successfully complete Foundations of Mathematics 20 have met the minimum graduation requirement for Math and may choose to proceed to Foundations of Mathematics 30.

**FONDEMENTS DES MATHÉMATIQUES 30**

Prerequisite: Fondements des mathématiques 20

The topics include financial mathematics; set theory and logic; counting methods; probability; polynomial functions; exponential and logarithmic functions; and sinusoidal functions.

**PRÉ-CALCUL 20**

Prerequisite: Fondements des mathématiques et pré-cal 10

The topics include sequences and series, trigonometry, quadratic functions and equations, radical expressions and equations, rational expressions and equations, absolute value and reciprocal functions, systems of equations and linear and quadratic inequalities. Students who successfully complete Pre-Calculus 20 have met the minimum graduation requirement for Math and may choose to proceed to Pre-Calculus 30.

**PRÉ-CALCUL 30**

Prerequisite: Pré-calcul 20

The topics include function transformations; radical, polynomial, rational, exponential, and logarithmic functions; the unit circle and trigonometric functions; function operations; and permutations, combinations and the Binomial Theorem. Students who successfully complete Pré-calcul 30 may choose to proceed to Calculus 30 (in English).

ADVANCED PLACEMENT: AP Calculus (AB) Pathway for French Immersion Students		
GRADE 10	GRADE 11	GRADE 12
<u>Pré-AP Fondements des mathématiques et pré-calcul 10</u>	<u>Pré-AP Pré-calcul 20</u>	AP Calculus 30 (taken in English)
<u>Pré-AP Fondements des mathématiques 20</u>	<u>Pré-AP Pré-calcul 30</u>	AP Calculus 30L (taken in English)
		<b>AP Calculus (AB) Exam Written in May (only available to be written in English)</b>

————— **MIEUX-ÊTRE** —————

**MIEUX-ÊTRE 10\***

Prerequisite: Complete Grade 9

Mieux-être 10 is designed in such a way that students investigate six components of wellness – physical activity, stress management, physical fitness, leisure, relationships, and healthy eating – and how these components relate directly to them as individuals. Physical activity and stress management are pursued most extensively with students designing, carrying out and evaluating action plans in these areas.

————— **FINE ARTS** —————

**ARTS VISUELS 10\***

Prerequisite: None

Students are encouraged to apply their knowledge of the elements of art and principles of design to their own work and discussions. As in previous years they explore ideas, materials, tools and techniques in order to present their ideas in a personal way. The cultural/historical (examination of art and artists from a variety of periods and cultures) creative/productive (making of art) and critical/responsive (analysis and criticism of one’s own and others’ art) components of the Arts Education curriculum are fundamental to the instruction of this course.

**ARTS VISUELS 20\***

Visual Art 20 is a continuation of the grade 10 program. As in previous years, the students explore ideas, materials, tools, techniques and present their ideas in a personal way (creative/ productive). Discussion and analysis of artists’ works are used to



further develop student skills and knowledge (critical/responsive). An understanding of various artists, artistic styles and cultures is encouraged through research, discussion and community/gallery visits (cultural/ historical).

### **ARTS VISUELS 30\***

Students in Grade 12 explore a variety of arts expressions through the creative/productive, cultural/ historical, and critical/responsive components of Arts Education. They increase their understanding of the languages and creative processes of visual art and convey their own ideas using a variety of materials, tools and techniques. An in-depth understanding of various artists, artistic styles and cultures is encouraged through discussion, research, and community/gallery visits. Throughout the class, students are challenged to interpret and analyze art works based on content found in the work.

## ————— PRACTICAL AND APPLIED ARTS —————

### **FABRICATION 10\***

Prerequisite: None

The objective of Welding 10 is to develop familiarity with the terms, tools, equipment and techniques of welding. Safety and the proper use of welding tools, materials and equipment are a priority in this class. Students learn the care of welding tools and equipment. Students will be exposed to Oxy/acetylene cutting, Oxy/acetylene, MIG and Arc welding. Students will have opportunity to practice and develop skills in these areas.

### **FABRICATION 20\***

Prerequisite: Fabrication 10

Students in Welding 20 will review the concepts learned in Welding 10. Students will continue to develop and expand skills in Oxy/acetylene cutting, Oxy/acetylene, MIG and Arc welding. Welding 20 students begin to weld in vertical and horizontal positions, learn to set up a welding work station and use evaluation skills to judge welding workmanship.

### **FABRICATION 30\***

Prerequisite: Fabrication 20

The Welding 30 course will further develop the welding shop skills acquired in Welding 10 and 20. There will be development of sheet metal welding and fabrication as well as a focus on project-based welding. The class will also continue the study of math applied to real world situations.

## ————— SCIENCES HUMAINES —————

### **SCIENCES HUMAINES 10**

Prerequisite: Sciences Humaines 9

The goal of this course is to lay the foundation for understanding the modern world. Thus, the students will study of the following themes: a revision of the Middle Ages and the Renaissance, the age of Exploration, Colonial Expansion, the period of Revolutions (agricultural, industrial, French), nationalism and imperialism.

### **HISTOIRE 20**

Prerequisite: Science Humaines 10

This course is intended to be a general survey of key events of this century. Thus, the following topics will be presented: World War I and its consequences (Versailles Treaty), the Russian Revolution, the Great Depression of the 20's and 30's, the rise of totalitarianism, World War II, the Cold War, N.A.T.O. (North Atlantic Treaty Organization) and contemporary world problems.

## ————— SCIENCES —————

### **SCIENCES 10**

Prerequisite: Science 9

The class is a general science course following the Pan Canadian Curriculum. The curriculum consists of 4 units: Sustainability of Ecosystems, Chemical Reactions, Motion in our World and Weather Dynamics. Students develop skills in

mathematical reasoning, scientific investigations, forming hypotheses, drawing good conclusions, graphing and analyzing data. There is an emphasis on developing scientific literacy, which involves science-related attitudes, skills and knowledge students need to improve their inquiry and problem-solving abilities.

Text: *Omnisciences 10*